

VAG Underground Hydrant for Low Depth DN 65 PN 10

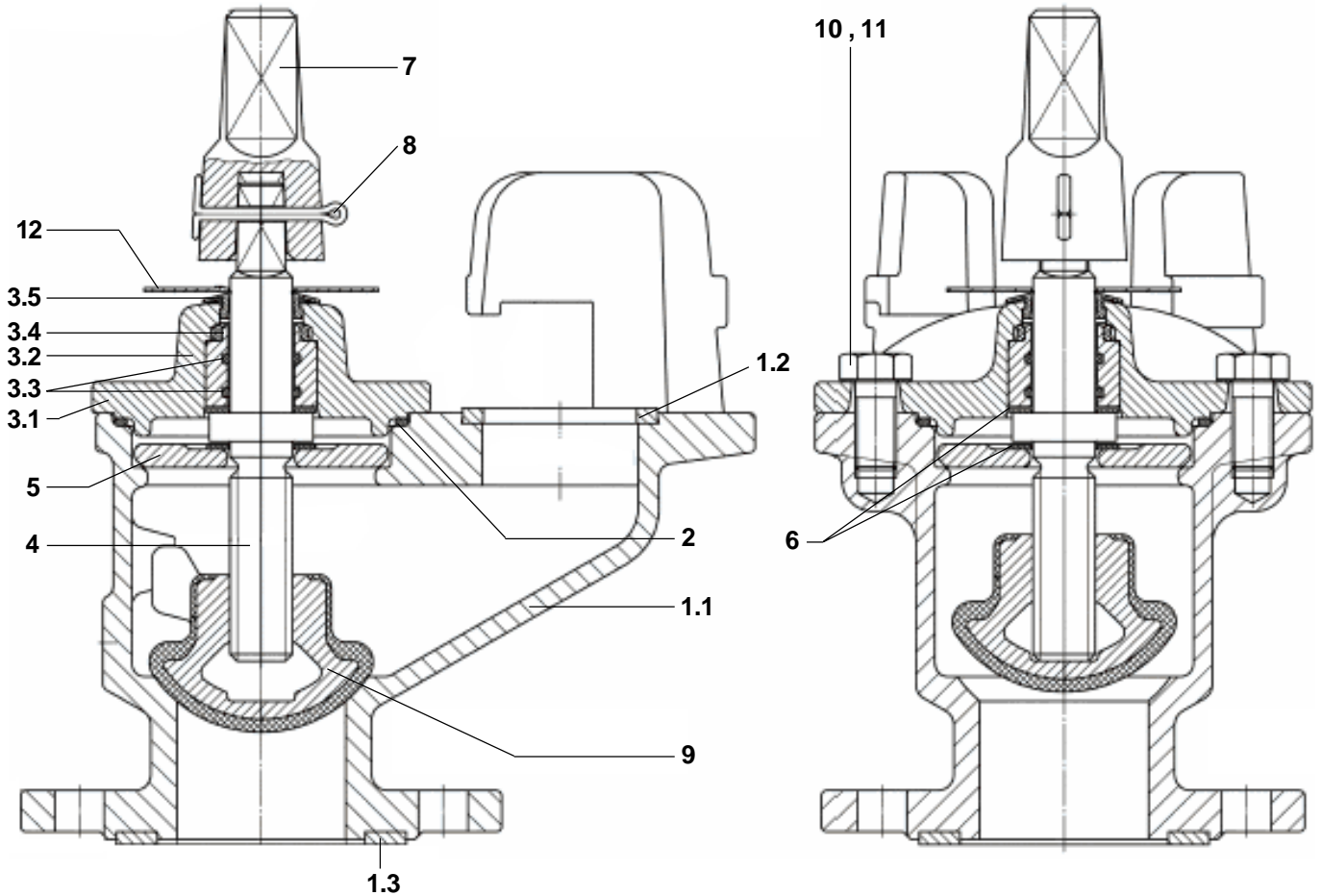

Teil Part	Benennung / Description					
1	Gehäuse kompl.	1.1	Gehäuse mit verst. Klaue	Body compl.	1.1	Body with outlet
		1.2	Klauensitzring		1.2	Outlet seat ring
		1.3	Gehäusedichtring		1.3	Body seat ring
2	O-Ring					O-ring
3	Aufsatz kompl.	3.1	Aufsatz	Cover compl.	3.1	Body
		3.2	Buchse		3.2	Bush
		3.3	O-Ring		3.3	O-ring
		3.4	Profiling		3.4	Profile ring
		3.5	Abstreifring		3.5	Wiper ring
4	Spindel					Stem
5	Spindel Abstützring					Stem support
6	Gleitscheibe					Sliding disc
7	Vierkantschoner					Stem square cap
8	Splint					Split pin
9	Kegel					Cone
10	6kt.- Schraube					Hexagon screw
11	Scheibe					Washer
12	Typenschild					Nameplate

Spare parts list

Part	Description	piece	code number
1.3*	Body seat ring	1	1-17-13406-850
	Cover, compl.		2-17-13140-017
2	O-ring	1	
3.1	Cover	1	
3.2	Bush	1	
3.3	O-ring	1	
3.4	Profile ring	1	
3.5	Wiper ring	1	
4	Stem (right-hand thread for counter clockwise closing Hydrant)	1	
4	Stem (left-hand thread for clockwise Hydrant)	1	1-17-13420-550
9	Cone clockwise closing	1	1-17-13408-005
9	Cone counter clockwise closing	1	1-17-13421-005

*** New - Delivery of Underground Hydrants for Low Depth will be carried out by the Mid of 2001 with „standard flange without body seat ring“**



VAG-Armaturen GmbH
Carl-Reuther-Straße 1
D-68305 Mannheim
P.O.B. 31 05 48
D-68265 Mannheim
Phone (0621) 749 - 0
Fax (0621) 749 - 2153
Internet: www.vag-armaturen.com

© by VAG-Armaturen GmbH