

# VAG SKR Slanted Seat Tilting Disk Check Valve PN 10 / 16

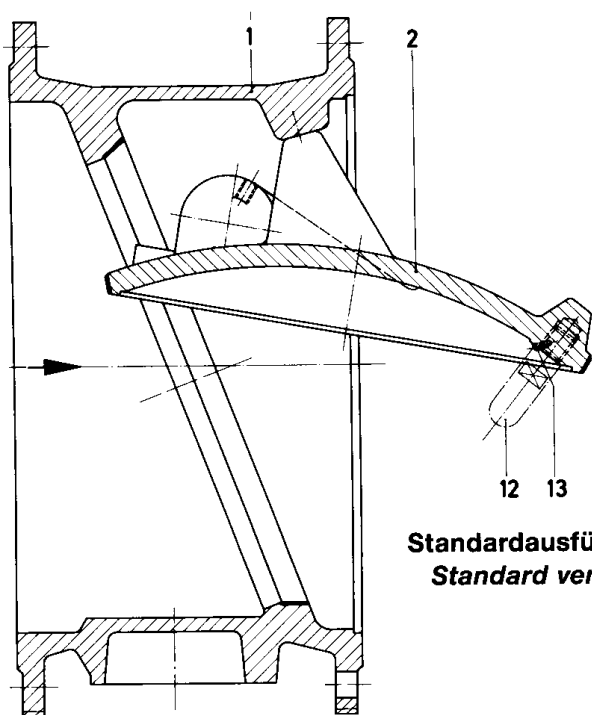

**Standardausführung/  
Standard version**

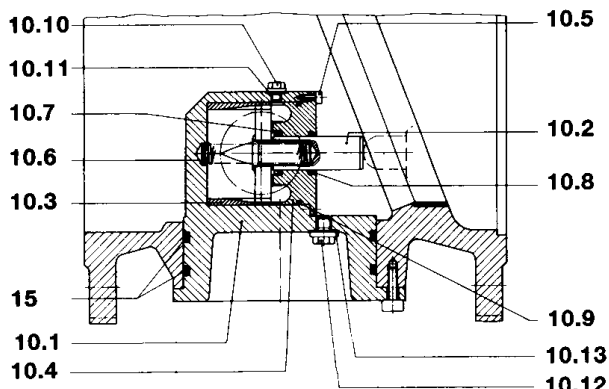
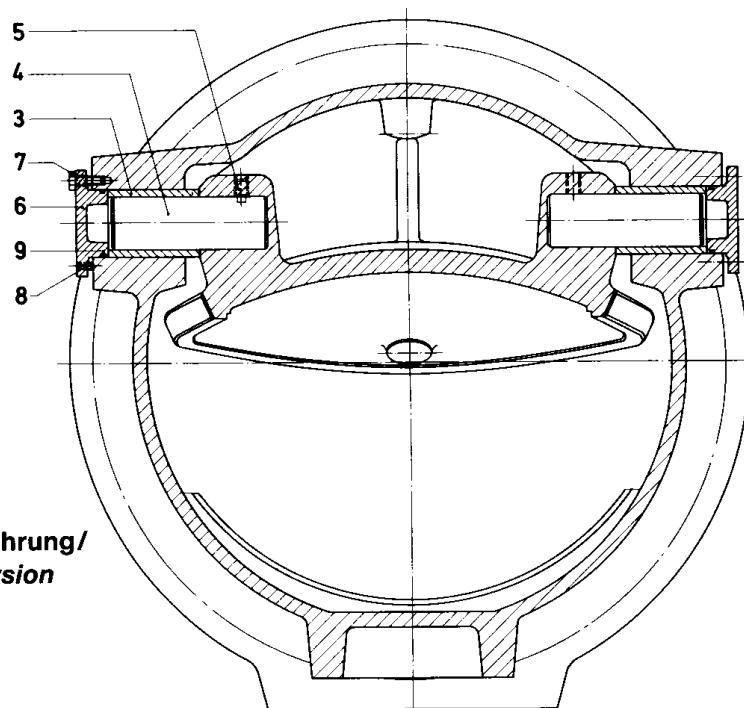

**mit innenliegender Endlagendämpfung  
with internal damper**

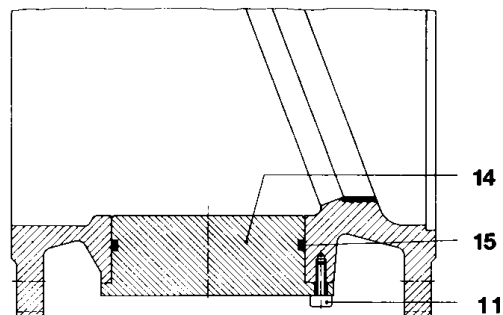

**mit Verschlussdeckel / with blind cover**

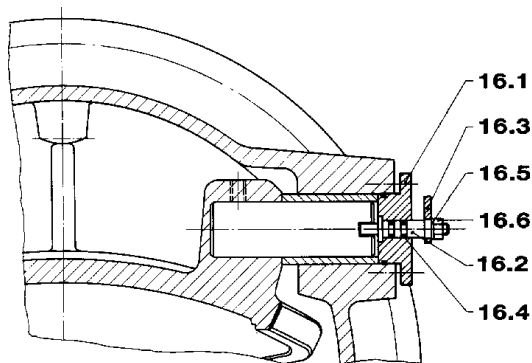

**mit Klappenstellungsanzeige/  
with position indicator**

Teil Part	Benennung / Description	
1	Gehäuse	Body
2	Klappenscheibe	Disk
3	Lagerbuchse	Bearing bush
4	Welle	Shaft
5	Gewindestift	Threaded pin
6	Lagerdeckel	Bearing cover
7	Sechskantschraube	Hexagon bolt
8	Gewindestift	Threaded pin
9	O-Ring	O-ring
10	Dämpfer	Damper
11	Zylinderschraube	Hex. socket head cap screw
12	Aufschlagbolzen	Impact bolt
13	Gewindestift	Threaded pin
14	Verschlussdeckel	Lower blind cover
15	O-Ring	O-ring
16.1	Lagerdeckel	Bearing cover
16.2	Zeigerwelle	Pointer shaft
16.3	Zeiger	Pointer
16.4	O-ring	O-ring
16.5	Scheibe	Washer
16.6	Sechskantmutter	Hexagon nut

## Spare parts list

Part	Description	piece	code number
<b>DN 200 / 250 PN 16</b>			
3	Bearing bush	2	1-25-14061-250
4	Shaft	2	1-23-32135-550
5	Threaded pin	2	1-75-33063-385
9	O-ring	2	1-75-33277-165
15	O-ring	2	1-75-33277-536
16.4	O-ring	2	1-75-33277-274
<b>DN 300 PN 16</b>			
3	Bearing bush	2	1-25-14062-250
4	Shaft	2	1-23-32136-550
5	Threaded pin	2	1-75-33063-385
9	O-ring	2	1-75-33277-564
15	O-ring	2	1-75-33277-531
16.4	O-ring	2	1-75-33277-274
<b>DN 350 PN 10</b>			
3	Bearing bush	2	1-25-14350-250
4	Shaft	2	1-23-32137-550
5	Threaded pin	2	1-75-33063-385
9	O-ring	2	1-75-33277-561
15	O-ring	2	1-75-33277-531
16.4	O-ring	2	1-75-33277-274
<b>DN 400 PN 16</b>			
3	Bearing bush	2	1-25-14092-250
4	Shaft	2	1-23-32005-550
5	Threaded pin	2	1-75-33063-383
9	O-ring	2	1-75-33277-495
15	O-ring	2	1-75-33277-548
16.4	O-ring	2	1-75-33277-274
<b>DN 450 PN 16</b>			
3	Bearing bush	2	1-25-14333-250
4	Shaft	2	1-23-32139-550
5	Threaded pin	2	1-75-33063-379
9	O-ring	2	1-75-33277-217
15	O-ring	2	1-75-33277-548
16.4	O-ring	2	1-75-33277-274
<b>DN 500 PN 16</b>			
3	Bearing bush	2	1-25-14333-250
4	Shaft	2	1-23-32139-550
5	Threaded pin	2	1-75-33063-379
9	O-ring	2	1-75-33277-217
15	O-ring	2	1-75-33276-886
16.4	O-ring	2	1-75-33277-274
<b>DN 600 PN 16</b>			
3	Bearing bush	2	1-25-14063-250
4	Shaft	2	1-23-24635-550
5	Threaded pin	2	1-75-33063-379
9	O-ring	2	1-75-33277-176
15	O-ring	2	1-75-33277-520
16.4	O-ring	2	1-75-33277-274
<b>DN 700 PN 16</b>			
3	Bearing bush	2	1-25-14481-250
4	Shaft	2	1-23-24612-550
5	Threaded pin	2	1-75-33063-379
9	O-ring	2	1-75-33277-178
15	O-ring	2	1-75-33277-518
16.4	O-ring	2	1-75-33277-274
<b>DN 800 PN 16</b>			
3	Bearing bush	2	1-25-14481-250
4	Shaft	2	1-23-24612-550
5	Threaded pin	2	1-75-33063-379
9	O-ring	2	1-75-33277-180
15	O-ring	2	1-75-33277-267
16.4	O-ring	2	1-75-33277-274
<b>DN 900 PN 10</b>			
3	Bearing bush	2	1-25-14508-250
4	Shaft	2	1-23-24789-550
5	Threaded pin	2	1-75-33063-271
9	O-ring	2	1-75-33277-180
15	O-ring	2	1-75-33275-372
16.4	O-ring	2	1-75-33277-274
<b>DN 1000 PN 10</b>			
3	Bearing bush	2	1-25-14597-250
4	Shaft	2	1-23-24714-550
5	Threaded pin	2	1-75-33063-271
9	O-ring	2	1-75-33277-182
15	O-ring	2	1-75-33277-552
16.4	O-ring	2	1-75-33277-274



VAG-Armaturen GmbH  
 Carl-Reuther-Straße 1  
 D-68305 Mannheim  
 P.O.B. 31 05 48  
 D-68265 Mannheim  
 Phone (0621) 749 - 0  
 Fax (0621) 749 - 2153  
 Internet: www.vag-armaturen.com

© by VAG-Armaturen GmbH