



PN 10
DN 50...300

Product Features

- Knife gate valve with multiple-orifice-plate for control purposes
- Asymmetric hole design to achieve an optimal flow characteristic
- Wafer-type valve for installation between pipe flange
- Compact, single monobloc body
- Completely chambered valve plate
- Leakproof in both flow directions
- Extreme easy operation torque, no additional gearing necessary
- Standard flush connection G 1/4"
- Suitable for underground installation
- With mounted handwheel
- New sealing principle - no lateral sealing on gate valve

Materials

- Body made of ductile cast iron EN JS 1030 (GGG-40)
- Knife, multiple-orifice-plate and yoke of stainless steel 1.4301
- Stem of stainless steel 1.4021
- Screws of stainless steel

Corrosion Protection

- Epoxy coated

Field of Application

- For pressure and flow control purposes
- Max. operation temperature: 50°C
- The max. operating pressures to KAT 2013-A

Alternatives

- Prepared for electric or pneumatic control actuator
- Pressure range PN 16

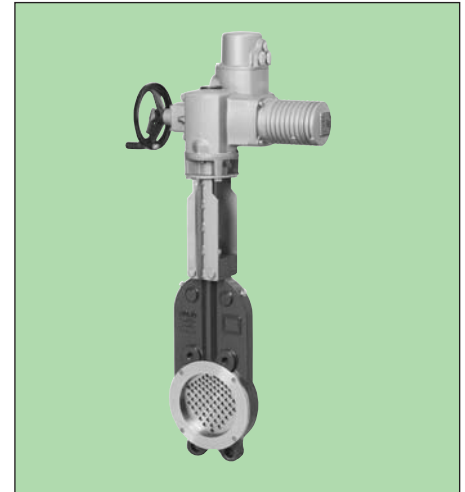

For ordering, please ask for questionnaire.

For information about installation, commissioning, operating and maintenance we kindly refer to our **"Installation and Operating Instructions - Valves"**.

Field of Use

Final Inspection Test in acc. with EN 12266

DN mm	PN bar	Max. operating pressure bar	Max. operating temperature for water °C	Test pressure with water	
				in body	in seat
50...300	10	10	50	15	11

Max. operating pressure on the reverse side of the valve plate

DN	50	65	80	100	125	150	200	250	300
Max. operating pressure (bar)	10	10	10	10	8	8	6	4	3

We reserve the right to make technical changes and use similar or higher-quality materials. Drawings are non-binding



Dimensions / weights

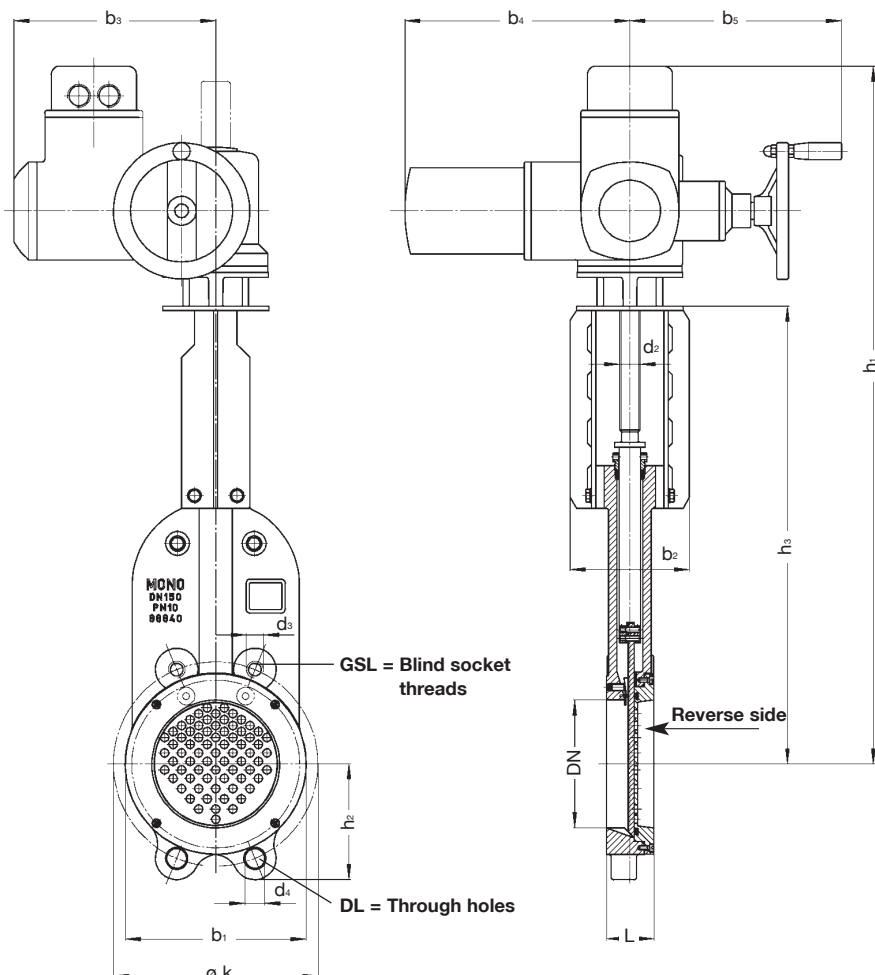

Dimensions in mm		50	65	80	100	125	150	200	250	300
DN		50	65	80	100	125	150	200	250	300
Construction	h ₁	582	616	644	682	754	819	924	1081	1227
	h ₂	60	70	90	105	115	140	160	170	180
	h ₃	300	334	362	400	472	537	642	799	945
	b ₁	102	121	138	156	172	212	272	324	385
	b ₂	130	130	140	140	140	140	160	180	180
	b ₃	237	237	237	237	237	237	237	237	237
	b ₄	264	264	264	264	264	264	264	264	264
	b ₅	249	249	249	249	249	249	249	249	249
	k	125	145	160	180	210	240	295	350	400
	L	43	46	64	64	70	56	60	68	78
	d ₂	Tr 24x5								
Flange drillings	No.	4	4	8	8	8	8	8	12	12
	Thread	M 16	M 16	M 16	M 16	M 16	M 20	M 20	M 20	M 20
Valve drillings	GSL	No. per side	2	2	2	2	2	2	4	4
		d ₃ (Blind socket threads)	M 16	M 16	M 16	M 16	M 16	M 20	M 20	M 20
	DL	No.	2	2	6	6	6	6	6	8
d ₄ (Through holes)		18	18	18	18	18	23	23	23	23
Turns/stroke		12.5	15	18.5	22	27.5	32	41.5	53.5	63.5
Weight	kg	33	34	37	38.5	43.5	45	54.5	71	90

We reserve the right to make technical changes and use similar or higher-quality materials. Drawings are non-binding